



# Side Discharge Bucket

FOR SKID-STEER LOADERS



PALADIN LIGHT CONSTRUCTION



*IT'S TIME TO THROW  
IN THE SHOVEL!*

Provides **Power & Precision**  
you need to lay Sand, Saw Dust, Feed  
and other materials for agricultural,  
road maintenance, and  
sandbagging applications!

# Side Discharge Bucket

## *Sand Discharge Bucket*

- Removable belt cover to keep weight off belt and reduce stalling
- 13-1/2" wide belt with 1/2" tall grouser
- Direct hydraulic drive for conveyor
- Right or left discharge
- Belt driven by cast steel sprockets
- Bucket edge drilled for bolt on edge
- No tool adjustment for discharge doors

## *Saw Dust Discharge Bucket*

- Material agitator to prevent bridging
- Direct hydraulic drive for agitator versus chain and sprocket drive
- 15" wide belt with 1" tall grouser

| Specifications      | Sand     | Sand     | Sawdust  | Sawdust  |
|---------------------|----------|----------|----------|----------|
| Model               | 10714-60 | 10714-72 | 10715-72 | 10715-84 |
| Weight (lbs)        | 805      | 915      | 1120     | 1300     |
| A. Width (overall)  | 60.0"    | 72.0"    | 72.0"    | 84.0"    |
| B. Height (overall) | 31.1"    | 31.1"    | 44.6"    | 44.6"    |
| C. Depth (overall)  | 40.0"    | 40.0"    | 46.5"    | 46.5"    |

### **Attachment Rating:**

Lift Capacity <9,500 lbs  
Operating Weight <11,000 lbs

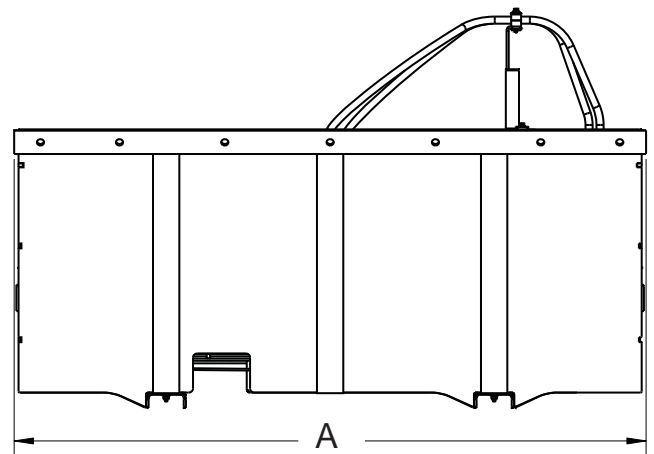
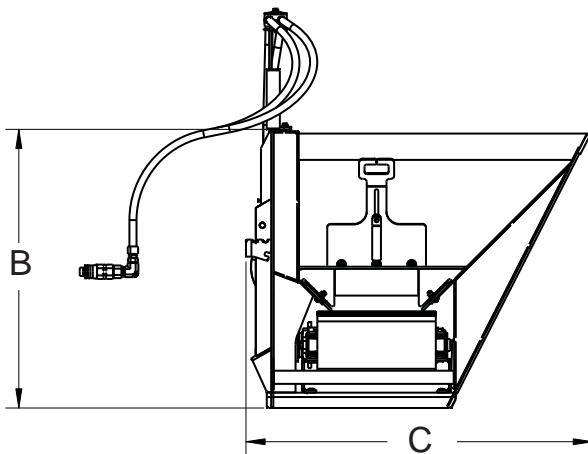

PH: (800) 456-7100

[www.paladinlightconstructiongroup.com](http://www.paladinlightconstructiongroup.com)

Side Discharge Bucket 0811-1

